



**U.S. RACK,™ Inc. - 2850 Falcon Drive, Madera, CA 93637 - 559-661-3050**

**--INSTALLATION AND USE INSTRUCTIONS--**

**WARNING: Do NOT attempt to install or use this rack without following all instructions.**

**SPECIFICATIONS and SAFE LOADING REQUIREMENTS**

The Strong-Ender Rack is designed to carry ladders or other rigid items not exceeding 250 lbs. of distributed weight on pickup trucks. **It is not designed to carry loads on unimproved or poorly maintained roads. It is not designed to carry loads where a weight of over 125 lbs. is concentrated on either the front or rear portion of the rack.** Excessive loads can pry the rack away from the bedrail lip. Watch this carefully to prevent damage or injury. U.S. Rack does NOT warrant truck bedrails or other truck parts against damage caused by the weight of excessive loads being applied to them when the rack is installed on a vehicle. **U.S. Rack is not responsible for injury or property damage resulting from the rack being improperly installed or loads being improperly tied down. If you cannot install and use this rack in accordance with all specifications and instructions, do not install or use this rack. Call our customer service at 1-888-877-2257 for assistance.**

**BE SAFE: Carrying any load can be hazardous.** All loads must be tied securely to the rack to prevent them from vibrating or sliding forward, backward, or laterally or being blown off or broken by the wind. **Make sure all parts of loads are securely tied down against unexpected winds or shocks and vibrations caused by unexpected road hazards such as potholes. Each day and each time you install or load the rack, inspect to ensure that all connections are tight. U.S. Rack is not responsible for injury or property damage resulting from cargo falling or being blown off a vehicle as a result of being improperly loaded or inadequately secured.** Ensure that loads do not extend more than 6 inches out from the side of the truck body. Loads extending beyond the rear bumper of the vehicle must be designated with a red flag (daylight) or red light (darkness) in accordance with the applicable state vehicle code. Do not allow any part of the rack or load to interfere with the driver's clear view in any direction or to interfere with the clear visibility of lights.

**INVENTORY**

Inventory the box to ensure all of the below parts are present as shown in FIG 1, below:

- A. Leg frames (x2)
- B. Extension arm (x2)
- C. Leg receiver tube (x2)
- D. Fronting Plate (x2)
- E. Spacer tubes: 3-inch long (x2), 5-inch long (x2)
- F. Base (x2)
- G. Hardware (some screws may already be threaded into place) : 5/16-18 x 2" button-head cap screws (x2); 5/16-18 x 3/4" button-head cap screws (x4); 5/16-18 x 1-1/4" button-head cap screws (x4), 5/16-18 x 2" carriage bolts (x2); flat washers (x6); 5/16-18 Nylon lock nuts (x6); 5/16-18 jam nuts (x4); 3/16" Allen wrench (x1)

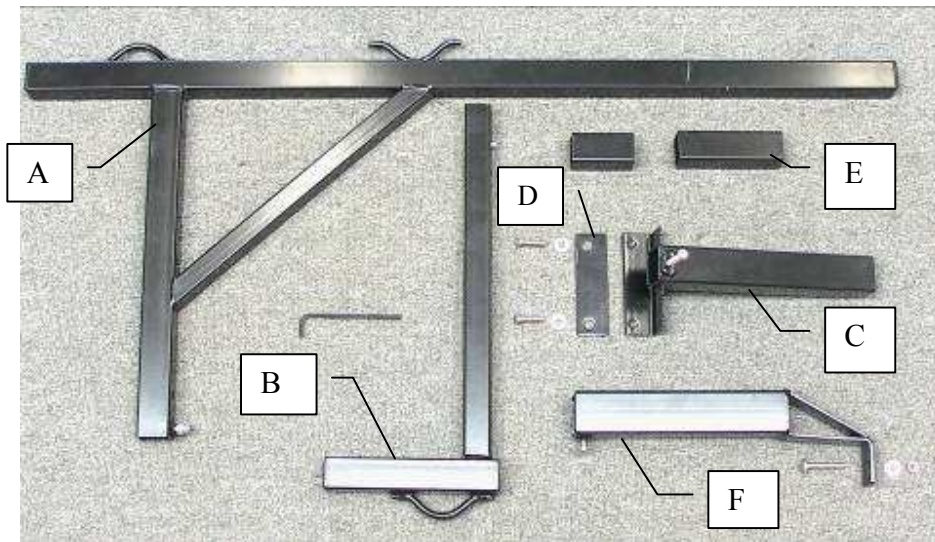

FIG 1



FIG 2

### ASSEMBLY

*You will need a tape measure, pencil, level, hex wrench, and an electric drill with 5/16-inch bit.*  
READ THROUGH ALL INSTRUCTIONS ONCE BEFORE YOU DO ANYTHING!-IT SAVES TIME

**Your safety is paramount.** Because manufacturing and shipping mistakes can occur, before assembling the rack, inventory and inspect all parts. Visually check each part to ensure it corresponds to the inventory list and photo and check all welds for signs of cracking or weakness. **If you do not have all the correct parts, if the rack you received does not appear to fit your model truck, or if any parts appear to be defective; STOP and do NOT install the rack.** Call customer service at 1-888-877-2257 to replace missing or defective parts or answer installation questions.

After inventorying parts and before installing the rack on your truck you need to assemble a few of the parts.

1. **ASSEMBLE MAIN BODY OF RACK.** Locate a leg frame (A) and an extension arm (B). Insert an extension arm into the leg frame so that the silver button snaps into one of the holes in the bottom of the leg frame as shown in Fig. 2. Insert a  $\frac{3}{4}$ -inch long screw with jam nut into threaded hole at end of leg frame and tighten screw with Allen wrench to prevent rattle. Tighten jam nut with hex a wrench to lock screw.
2. **EXAMINE FRONTING AND BACKING PLATES AND SPACER TUBES.** Examine a leg receiver tube (C). Thread a 2-inch long screw a few turns into the hole at the top of the tube. Examine a fronting plate (D). Place it with the holes toward the top on the shelf formed at the top of the receiver tube as shown in Fig. 3. See how the holes in each fronting plate align with those in the backing plate at the top of the leg receiver tube. Examine the spacer tubes (E). They will be used later.
3. **ASSEMBLE RECEIVER/BASE.** Locate a base tube and screw a  $\frac{3}{4}$ -inch long screw with jam nut a few threads into the hole at the top of each base. Now hold the receiver tube above the base and orient them so that the screws are facing in the same direction. Form a receiver/base assembly by inserting the leg receiver tube into the base as shown in Figs. 4, 5 or 6.
4. **ASSEMBLE SECOND SET OF PARTS.** Assemble remaining parts in the same manner as the first.



FIG 3



FIG 4



FIG 5



FIG 6

### INSTALLATION

5. **PLACE THE RECEIVER/BASE ASSEMBLY.** Park your truck in a level place. Retrieve a fronting plate and one of the receiver/base assemblies. Open the tailgate of your truck and step up inside with these parts. Locate yourself near the front of the bed on passenger side. Orient the receiver/base assembly so both screws face you. Note that the two parts have the freedom to slide together or apart. Place the assembly in contact with the side of the bedrail in the desired location. Allow the base to slide down so the foot rests flat on the floor. Slide the backing plate at the top of the receiver tube behind the bedrail lip and lift it up as far as possible as shown in FIG 4. Place the fronting plate on the receiver with holes toward the top. Press the fronting plate against the outside surface of the bedrail lip so the holes in the fronting plate and backing plate are aligned on opposite sides of the bedrail lip as shown in FIG 5. Mark the bedrail at center of the holes in the fronting plate. Remove the assembly.

*If you have an over-the-rail bedliner, you must access the area behind the lip of the bedrail. Using the backing plate as a template, align the top of the backing plate with the top of the bedrail and make a pencil mark below the bottom of the backing plate. Cut a horizontal slit in bedliner at this line, which should be below the lip of the bedrail. Before cutting, however, either remove the bedliner or probe to ensure that where you are about to cut is free of obstructing sheet metal.*

6. **ATTACH RECEIVER/BASE ASSEMBLY TO BEDRAIL.** Using an electric drill with a 5/16 diameter bit, drill a hole in the bedrail at each pencil mark. Replace the assembly as before and align the holes of the backing plate and the holes of the fronting plate with the holes drilled in the bedrail. Insert a 1-1/4-inch screw with washer into each hole and tighten moderately with the Allen wrench as shown in FIG 7.
7. **SET HEIGHT OF RACK.** Ensure the receiver/base is plumb and that the base sits flat on the floor of the bed; then orient the leg frame as shown in FIG 8 and insert the bottom of the leg frame down into the receiver until it rests at the bottom of the base. You can determine the height of the rack in relation to your cab by using a level as shown in FIG 9. The cross-bar of your rack should be at least two inches above you roof. If your rack is higher, you may want to shorten the rack to have a more sleek appearance. You may cut the bottom of the leg frame to reduce the height. In other cases you may find that the top of the rack is too low. In such cases remove the leg and insert the long, the short, or both spacer tubes down into the receiver tube to achieve the desired height. Re-insert the leg frame into the receiver tube until it rests on the spacer tubes. **FOR SAFETY YOU MUST ENSURE, HOWEVER, THAT THE LEG FRAME REMAINS INSERTED AT LEAST 5 INCHES INTO THE RECEIVER.** Now tighten the screws in the front of the receiver and the front of the base enough to hold the leg frame straight up and to prevent the base and receiver from sliding up and down.
8. **ATTACH BASE TO FLOOR.** Again make sure that the leg frame is at the desired height and properly seated in the base. Use the level to confirm that the leg frame is plumb. Now with the base sitting firmly on the floor of the bed, make a pencil mark on the floor of the truck bed at the center of the square hole in the base. Move the base aside and make a 5/16-inch diameter hole in the bed at this mark with an electric drill, ensuring first that the space below is clear of wiring, cables, gas tanks or other obstructions. Move the base back into position, and then insert a carriage bolt through the square hole in the floor and apply a washer and nylon lock nut on the bottom side; tighten nut firmly with a hex wrench. See FIG 7, below.

9. **ATTACH MAIN BODY OF RACK TO RECEIVER.** Loosen the 2-inch long screw in the receiver and remove the leg frame. Notice that there is a mark on the leg where the 2-inch screw was tightened. Using the electric drill, make a 5/16 diameter hole at the mark through ONLY ONE SIDE of the leg frame. Reinsert the leg frame and tighten the 2-inch screw again. This time the screw should pass through the first wall of the leg frame tube and make contact with the interior of the second wall. As you tighten it, the screw will push against the back wall of the leg frame and pin it against the wall of the receiver tube.

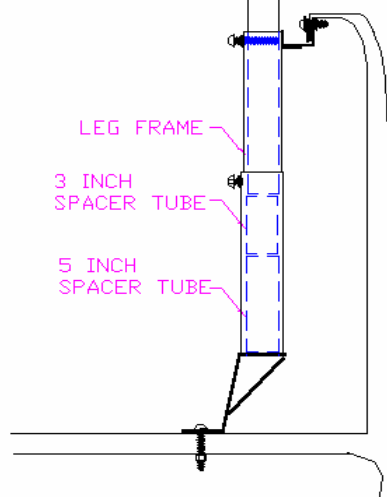

FIG 7

10. Install the rear portion of the rack near your tailgate in the same manner as the front portion of the rack. Tighten all screws firmly. Firmly tighten all jam nuts on the 3/4-inch screws on the leg frames and on the bases. For extra security, apply the 4 additional nylon lock nuts to the 1-1/4 inch screws behind the lip of the bedrail. When installed, both elements of the rack should sit firmly on the truck bed without moving. Do NOT carry any cargo without tying it securely to the rack; frequently check tension on cargo tied down to the metal loops and hooks provided as shown in FIG 10.



FIG 8



FIG 9



FIG 10

## WARRANTY

U.S. Rack™ products are warranted for a period of one year against all structural defects in materials and workmanship provided that they are assembled, installed, and used in accordance with all manufacturer's specifications and instructions. U.S. Rack **cannot warrant the powder-coating** on its products. Although the surface of the steel is electro-chemically treated to inhibit rust prior to powder-coating, normal outdoor use of your rack will result in scratching and weathering of surfaces, exposing the steel to moisture; therefore, maintenance on your rack will be required. To prevent rust, spot paint any scratches or breaks in the surface with a high quality metal paint.

**Any returned merchandise must be shipped in the original box and packaged to prevent damage.** See return policies and procedures at <http://www.usrack.com/service.html>